



AUTOMATICHE
AUTOMATIC

**TENERIFE
LIPARI
LINOSA
KEA**



PROGETTATE PER TE

AUTOMATICHE

TRASMISSIONE A CINGHIA

TRASMISSIONE A INGRANAGGI

- Tecnicamente avanzate con grandi capacità e precisione di taglio
- Dotate di carrello scorrevole montato su boccole autolubrificanti e cuscinetti a sfera
- Costruite in lega speciale di alluminio anodizzato, brillante e igienico e basamento in acciaio inox AISI 304
- Pannello di controllo con display e possibilità di impostare numero di fette (fino a 999), al termine del taglio dell'ultima fetta il carrello portasalumi si riposiziona automaticamente a inizio corsa
- Regolazione della lunghezza di corsa del carrello in funzione del tipo di merce
- Dotata di due motori indipendenti, uno per la lama e uno per il movimento del carrello
- Possibilità di passaggio dal taglio automatico a quello manuale anche con la macchina in movimento
- Disponibili con molteplici versioni di piatto:

Piatto normale, di grandi dimensioni, adatto per ogni tipo di prodotto

Piatto con braccio stringisalume speciale, con piano scorrevole, ideale per prosciutto crudo e ogni altro insaccato

Piatto con aste regolabili, adatto per il taglio di più pezzi contemporaneamente

AUTOMATIC

BELT TRANSMISSION

GEAR TRANSMISSION

- *Technologically advanced, with great cutting capacity and precision*
- *Equipped with sliding carriage assembled on self-lubricating bushings and ball bearings*
- *Made of special anodized aluminum alloy, shiny and hygienic; stainless steel AISI 304 base*
- *Control panel with display. It is possible to set the number of slices (up to 999); once the last slice is cut the carriage automatically draws back to its initial position*
- *The length of the carriage movement can be adjusted according to the type of product*
- *Equipped with two independent motors, one for the blade and the other for carriage movement*
- *Possibility to switch from automatic to manual slicing even while the machine is at work*
- *Available with different plate versions:*

Regular plate, large, suitable for all kinds of products

Plate with special squeezing arm with sliding surface, perfect for prosciutto and other cold cuts

Plate with adjustable shafts, suitable for slicing more than one piece simultaneously

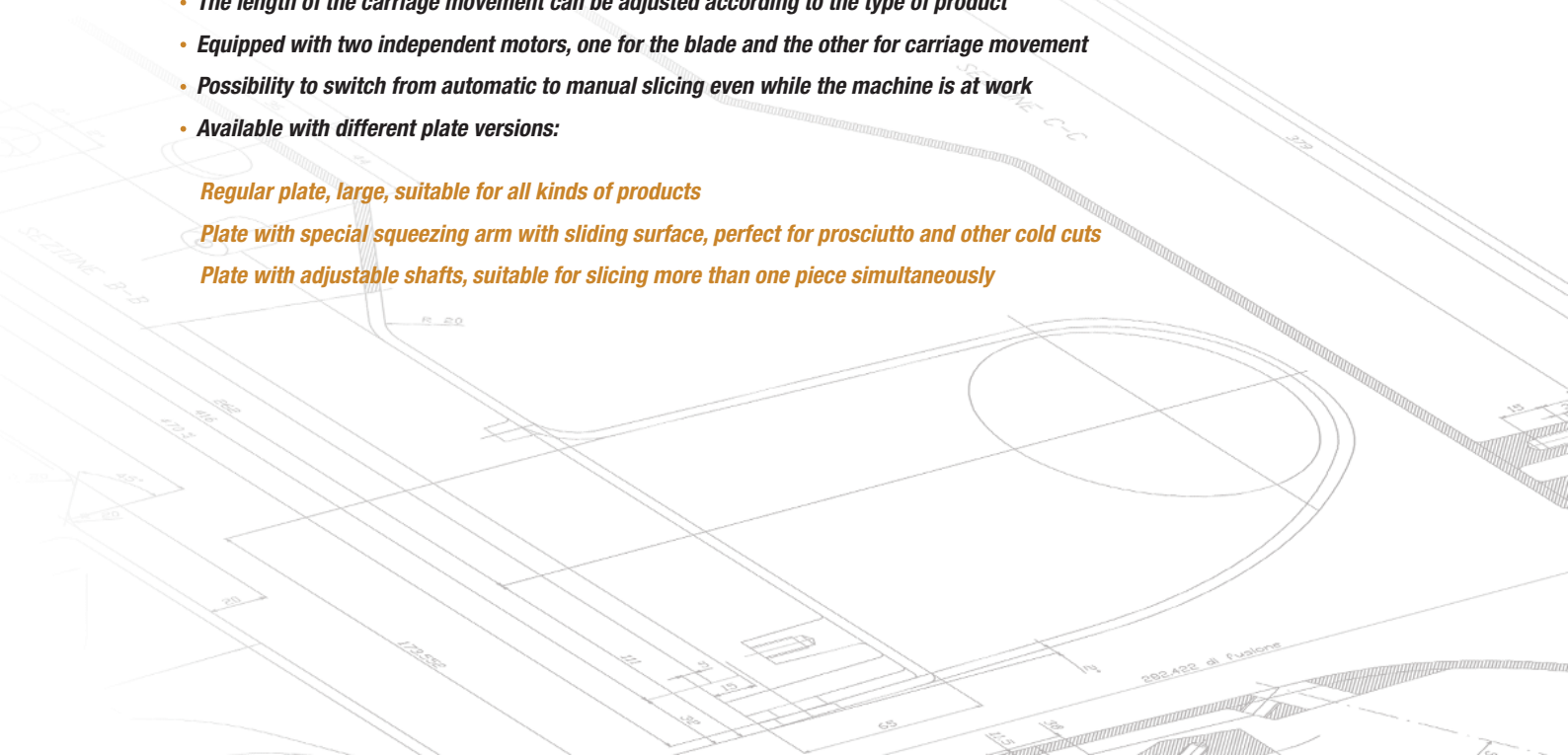

TENERIFE TGN300

TENERIFE TGN330

- **Trasmissione a cinghia**
- **Disponibile in due versioni di lama: 300 e 330 mm**



- **Belt transmission**
- **Available in two versions (blades): 300 and 330 mm**

LIPARI TG350

LIPARI TG370

- **Trasmissione a cinghia**
- **Disponibile in due versioni di lama: 350 e 370 mm**



- **Belt transmission**
- **Available in two versions (blades): 350 and 370 mm**

KEA TGI300

KEA TGI330

KEA TGSPi350

- **Trasmissione a ingranaggi**
- **Disponibile in tre versioni di lama: 300, 330 e 350 mm**



Pannello di controllo con display

- ***Gear transmission***
- ***Available in three versions (blades): 300, 330 and 350 mm***



LINOSA TGI350

LINOSA TGI370

LINOSA TGI390

- **Trasmissione a ingranaggi**
- **Disponibile in tre versioni di lama: 350, 370 e 390 mm**

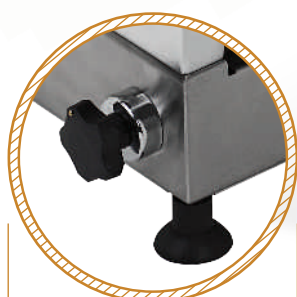
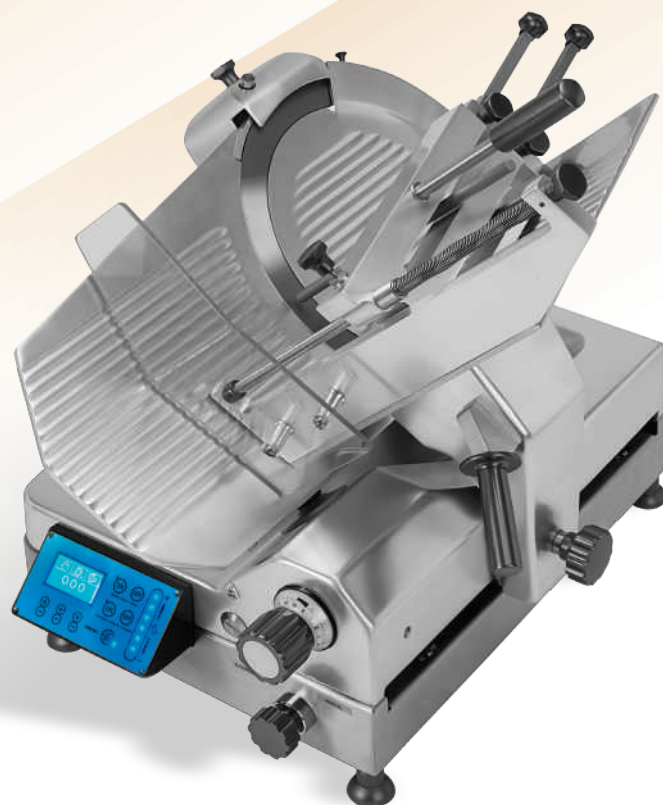

funzione taglio
automatico o manuale

automatic or manual
slicing function

- **Gear transmission**
- **Available in three versions (blades): 350, 370 and 390 mm**



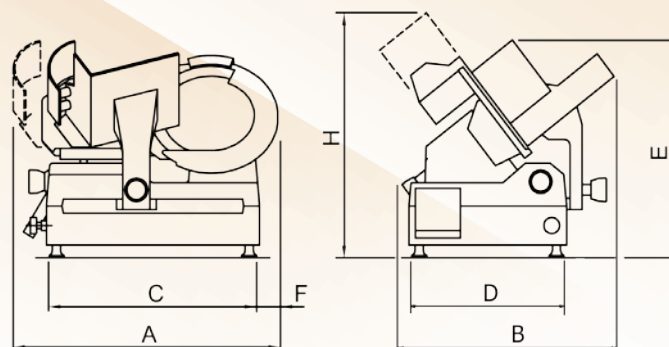

Modello Model	Diamentro Lama (mm) Blade Diameter (inch)	Giri Lama (giri/min.) Blade Revolution (rpm)	Motore Monofase 230 V/50 Hz (W) Single-phase Motor (HP)	Motore Trifase 400 V/50 Hz (W) Three-phase Motor (HP)	Corsa Carrello (mm) Run of Carriage (mm)	Spessore Taglio (mm) Cut Thickness (mm)	Capacità di Taglio Tondo (mm) Round Cut Capacity (mm)	Capacità di Taglio HXL (mm) Cut Capacity HXL (mm)	Peso Netto (Kg) Net Weight (Kg)	Peso Lordo (Kg) Gross Weight (Kg)	Dimensioni Imballo (mm) Shipping (mm)	Dimensioni (mm) Dimensions (mm)						
												A	B	C	D	E	F	H
TENERIFE TGN300	300/11,8	275	230/0,31	230/0,31	305	0-14	215	175x250	41	47+6	73x63xH53+12	690	540	480	340	585	80	620
TENERIFE TGN330	330/13,0	275	230/0,31	230/0,31	310	0-14	225	195x250	43	48+6	73x63xH53+12	690	540	480	340	585	80	620
LIPARI TG350	350/13,8	220	370/0,50	370/0,50	375	0-14	245	205x280	70	76+6	80x71xH70+12	790	585	580	400	595	60	675
LIPARI TG370	370/14,6	220	370/0,50	370/0,50	375	0-14	255	215x280	71	77+6	80x71xH70+12	790	585	580	400	605	60	675
LINOSA TGI350	350/13,8	230	370/0,50	370/0,50	370	0-14	240	200x280	70	78+6	80x71xH70+12	810	600	600	450	610	70	700
LINOSA TGI370	370/14,6	230	370/0,50	370/0,50	370	0-14	250	210x280	71	79+6	80x71xH70+12	810	600	600	450	610	70	700
LINOSA TGI390	390/15,4	230	370/0,50	370/0,50	370	0-14	255	215x280	72	80+6	80x71xH70+12	810	600	600	450	610	70	700
KEA TGI300	300/11,8	270	250/0,34	250/0,34	335	0-14	215	175x260	50	56+6	73x63xH53+12	690	540	500	350	550	90	600
KEA TGI330	330/13,0	270	250/0,34	250/0,34	335	0-14	220	190x250	54	60+6	73x63xH53+12	690	540	500	350	550	90	600
KEA TGSPI350	350/13,8	270	250/0,34	250/0,34	335	0-14	230	200x250	57	62+6	73x63xH53+12	690	540	500	350	550	90	600



via C. Battisti, 10 · 21040 Jerago con Orago (VA) · tel. +39 0331 217292 · fax +39 0331 219223

www.omsaffettatrici.com