



minipack® - torre
Packaging machines and systems

MVS45L XP

TROLLEY VACUUM - SEALING BAR 450 MM - PROCESS TRACKING AND LABELLER

VACUUM MACHINE WITH CARRIAGE



DESCRIPTION

The new series of **chamber vacuum sealers MVS XP** allows the tracing of the vacuum in the packaging: an innovative and revolutionary feature for the internal vacuum, typical of the pioneering style by **minipack®-torre**.

In fact, some of the packaging machines offer the possibility to print for each operation a label in which all the most important packaging information is provided.

The **vacuum packaging machines** in this series also feature a new avant-garde display, which allows you to access a wide range of innovative features for the food industry. Thanks to user-friendly technology and ease of use, the control panel allows you to quickly set up all packaging options and to easily program the technical assistance interventions.

minipack®-torre S.p.A.

Sede legale - Via Provinciale, 54 - 24044 DALMINE (BG) Italy

P.IVA - C.F.: 01633550163 - Capitale sociale 619.200,00 i.v. - Reg. Imprese di Bergamo 01633550163 - REA n. 224151



The whole new series of **chamber vacuum sealers XP** is CE/ETL/NSF Certified.

TECHNICAL FEATURES

Electrical power supply	V	120/230
Phase	ph	1
Dimensions of sealing bars	mm	MVS45L XP FRONT B. 450 (no. 1 front) MVS45L XP 2 SIDE B. 450 (no. 2 side)
Packaging cycle (Vacuum 20%)	sec.	Vacuum= 24 - Air re-immission= 8
Vacuum pump	mc/h	20
Work surface height	mm	889
Machine dimensions with the lid open	mm	546x676x h.1200
Machine dimensions with the lid closed	mm	546x676x h.1012
Machine weight (Net/Gross)	kg	104/129
Available chamber dimensions (Tank+lid)	mm	MVS45L XP FRONT B. 466x405.5x h.226 MVS45L XP 2 SIDE B. 351x466x h.226

minipack@-torre shall not be held liable for typos or printing errors in this catalogue. It also reserves the right to make changes to the specified features without prior notice. All trademarks are property of their respective owners and are hereby acknowledged.

TECHNICAL DRAWING

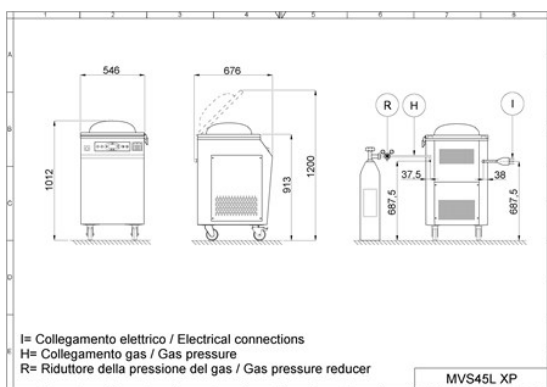

A SERIES OF UNIQUE BENEFITS

- Newly-designed liquid crystal **CONTROL DISPLAY**: it provides extensive packaging information, quick and easy settings and option of programming technical work servicing on the machine at the premises of the end

minipack@-torre S.p.A.

Sede legale - Via Provinciale, 54 - 24044 DALMINE (BG) Italy

P.IVA - C.F.: 01633550163 - Capitale sociale 619.200,00 i.v. - Reg. Imprese di Bergamo 01633550163 - REA n. 224151



user

- **PRELIMINARY DIAGNOSIS** of technical issues on the machine directly from the display via the check-up function without opening the machine
- Option of retrieving the types of products that need to be packaged, divided by macro-categories (meat, fish, cheeses, vegetables, etc.)
- Option of entering the type of inert gas (e.g. FOOD1-2-3) and setting (in a submenu) the percentage of gases forming the mix (e.g. O2=10% N=70% CO2=20%), thereby transferring the set data onto the label. This is a top function in case of external mixers
- Option of selecting the subcategories (e.g. meat, veal, beef, chicken, pork, etc.) for each product macro-category
- Automatic setting for packaging steps with suggested or default values after the selection of the subcategories, while the expiry date remains to be set (optional step)
- **EASY PULSE** function to make programming easier, with the benefit for the operator of recalling functions that have already been set and settings
- Printing option (to be programmed) to issue the vacuum certification label and choose the number of copies to be applied on the individual items of packaging created during each cycle
- Electronic **SOFT AIR** designed with various speed settings. It allows the air gradually go back into the chamber without letting the packaging suddenly collapse (ideal for products with sharp areas)
- **CP-CONDITIONING PROGRAM** function to start the pump. It is used to eliminate oil-liquid emulsions that settle in the pump's tank. Recommended after the machine has not been used for extended periods of time
- **EXTERNAL VACUUM** option to create a vacuum inside a container outside the machine and connected to the tank with a tube
- The vacuum can be created by setting the time and disabling the vacuum sensor detection.

MAIN NEW FEATURES SHOW ON THE DISPLAY

DATE: based on the clock

LANGUAGE: 8 languages

OPERATOR: 0001, the equivalent of Mr. Mario Rossi

WEBSITE

VACUUM DETECTION: % or in mbar (very useful for chefs)

LABEL: YES; NO - printing option with label

SERVICE: e-mail of the retailer with telephone number

CYCLE COUNTER: counter the machine cycles (cannot be edited)

OIL CYCLES: pump oil change

CYCLES OFF: indicates routine maintenance



minipack® - torre
Packaging machines and systems

TOT. HOURS: hours of operation of the machine

TOT. HOURS: hours of operation of the pump.

OVER TO THE CHEF

Creativity and efficiency are combined in the new vacuum machines by **minipack®-torre**.

Designed to optimise time and work in professional kitchens, they come with unique features on the market. The special marinade programme that makes it easier to introduce spices, seasoning, sauces and syrups, the program designed for sealing food whilst it is still hot, the automatic printing of a label in accordance with the HACCP protocol: key new features that, along with the option of cooking vacuum-sealed food at low temperatures, represent invaluable help for any chef.

The extra help you can count on in the kitchen.

VERSIONS

MVS 45L XP FRONT B. (MVS 45L XP front bar)

MVS 45L XP 2 SIDE B. (MVS 45L XP 2 side bars)

minipack®-torre S.p.A.

Sede legale - Via Provinciale, 54 - 24044 DALMINE (BG) Italy

P.IVA - C.F.: 01633550163 - Capitale sociale 619.200,00 i.v. - Reg. Imprese di Bergamo 01633550163 - REA n. 224151